

**HD-
A6V200**



Hydraulic valves



**Axial piston-bent axis design
variable displacement motor**

Catalogue



BELJING HUADE HYDRAULIC INDUSTRIAL GROUP CO.,LTD.

NOTES

1. In order to guarantee trouble-free and efficient operation, the hydraulic fluid in a hydrostatic system should be selected carefully according to the actual working conditions during the design of the system. All mineral oil based fluids are suitable to a greater or lesser degree for application in axial piston units. Their basic classification of application results from the relationship between the water, viscosity and temperature, with consideration of oxidization and corrosion protection, material compatibility, air and water separation characteristics.

2. In order to guarantee a long service life for the installation, good and reliable filtration is necessary. The hard particle contamination of fluid may not exceed a level determined by:

Class 9 to NAS 1638

Class 6 to SAE

Class 18/15 to ISO/DIS 4406

When the fluid temperature is too high, the required minimum degree of cleanliness is:

Class 8 to NAS 1638

Class 5 to SAE

Class 17/14 to ISO/DIS 4406

3. In order to select the correct fluid, it is necessary to know the operating temperature in the circuit in relation to the ambient temperature—in an open circuit and the tank temperature.

4. Important: The leakage oil(case drain oil)temperature is influenced by pressure and pump speed and is always higher than the circuit temperature. However, at no point in the circuit may the temperature exceed 90°C.

If it is not possible to comply with the above conditions because of extreme operating parameters or high ambient temperatures, please consult us.

5. The minimum pressure at the suction port of the motor ≥ 0.08 Mpa(absolute pressure), and the drain pressure(max. permissible casing pressure)is 0.2 MPa(absolute pressure). The pressure in the housing must be the same or greater than the external pressure on the shaft seal.

6. Installation position: in general, the upper point on the motor housing must be below the minimum oil level of the tank. If you would like to install above the minimum oil level, please indicate when order.

All technical information in this catalogue, for reference only.

Any special request please inquire our technical department.

Any changes,without notice.

BEIJING HUADE HYDRAULIC INDUSTRIAL GROUP CO. ,LTD.	Variable Displacement Motor HD-A6V200 For open and closed circuits axial tapered piston,bent axis design	
	Size 200	Peak pressure up to 45MPa



Features:

- For use in mobile and stationary application areas
- The wide control range enables the variable motor to satisfy the requirements for high speed and high torque
- The displacement is infinitely variable from V_{gmax} to the $V_{gmin} = 0$
- The output speed depends on the flow of the pump and the displacement of the motor
- The output torque increases with the pressure differential between the high and low pressure side and with increasing displacement
- Wide control range with hydrostatic transmission
- Wide selection of control devices
- Cost savings through elimination of gear shifts and possibility of smaller pumps
- Compact, robust bearing system with long service life
- High power density
- Good starting characteristics
- Low moment of inertia
- Wide swing range of the clino-axis

Variable Displacement Motor HD-A6V200

Type code

HD — A6V 200 EP2D 6 B A 2

Company

HUADE HYDRAULIC

Type

Variable displacement motor

A6V

Size

Displacement $V_{gmax}(m^3/r)$

200

Control device

Electric proportional variable-volume

With proportional solenoid 24V

EP2

With constant pressure control $\Delta P=1Mpa$

EP2D

Assembly Type

Description of control device and unit dimensions

2

Shaft end

Spline shaft DIN 5480

A

Mounting flange

SAE flange, on side

F

SAE Flange, on back

B

Series

Series

6

Ordering example :

HD-A6V200EP2D6BA2

Axial piston variable displacement motor A6V ,size 200,Electric proportional variable-volume control,24, With pressure constant control,series 6,SAE flange connections on back,splined shaft A,assembly type 2

Variable Displacement Motor HD-A6V200

Technical data

Operating pressure range:

Pressure on port A or B:

Nominal pressure $P_N = 40 \text{ MPa}$

Peak pressure $P_{max} = 45 \text{ MPa}$

Total pressure (press.A+press.B), $P_{max} = 70 \text{ MPa}$

Case drain pressure

It is recommended that the average, continuous case drain pressure at operating temperature 0.3Mpa absolute not be exceeded.

Short-term ($t < 5 \text{ min}$) pressure spikes of up to 1Mpa absolute are permitted.

Temperature Range:

The FKM shaft seal ring is possible for case temperatures of

-25 °C to +115 °C

Note:

For application case below -25 °C, an NBR shaft seal ring is necessary (possible temperature range: -40 °C to +90 °C)

Viscosity Limit

$v_{min} = 5 \text{ mm}^2/\text{s}$

short-term ($t < 3 \text{ min}$) at max.perm.temperature of

$t_{max} = +115 \text{ °C}$

$v_{max} = 1600 \text{ mm}^2/\text{s}$

short-term ($t < 3 \text{ min}$) at cold start

($P \leq 3 \text{ MPa}, n \leq 1000 \text{ r/min}, t_{min} = -40 \text{ °C}$)

Oil Viscosity Range

$$v_{opt} = 16 \sim 36 \text{ mm}^2/\text{s}$$

Fluid recommendation

Operating recommended

Viscosity grade temperature to DIN51519

30-40 °C	VG22=22 mm ² /s	at40 °C
40-50 °C	VG32=32 mm ² /s	at40 °C
50-60 °C	VG46=46mm ² /s	at40 °C
60-70 °C	VG68=68 mm ² /s	at40 °C
70-80 °C	VG100=100 mm ² /s	at40 °C

Filtration

The finer the filtration the better the achieved purity grade of the pressure fluid and the longer the life of axial piston unit. In order to guarantee reliable function, the operating fluid must be maintained to cleanliness grade of minimum purity grade of: 9 to NSA 1638, or 18/15 to ISO/DIS 4406.

At very high temperatures, the hydraulic fluid is 8 to NSA 1638, or 17/14 to ISO/DIS 4406.

Speed Range

No limitation on minimum speed. If high uniformity of rotation is required, n_{max} should not be less than 50r/min. See technical data for maximum speed n_{max} .

Calculation of size

Flow [L/min]

$$n = \frac{Q \cdot 1000 \cdot \eta_v}{V_g} \quad Q = \frac{V_g \cdot n}{1000 \cdot \eta_v} \quad \text{[r/min]}$$

$$\text{Output torque } M = \frac{V_g \cdot \Delta p \cdot \eta_{mh}}{2\pi}$$

$$\frac{1.59 \cdot V_g \cdot \Delta p \cdot \eta_{mh}}{10} \quad \text{[Nm]}$$

$$\text{or } M = \frac{K_m \cdot \Delta p \cdot \eta_{mh}}{10} \quad \text{[Nm]}$$

$$\text{Power } P = \frac{2\pi \cdot T \cdot n}{60000} = \frac{T \cdot n}{9549} = \frac{Q \cdot \Delta p \cdot \eta_t}{60} \quad \text{[kW]}$$

V_g = geom. displacement [ml/r]

M = torque [Nm]

Δp = pressure differential [MPa]

n = speed [r/min]

η_v = volumetric efficiency

η_{mh} = mech-hydr. efficiency

η_t = overall efficiency ($\eta_t = \eta_v \cdot \eta_{mh}$)

Variable Displacement Motor HD-A6V200

Technical Date

Size			200
Displacement	V_{gmax}	ml/r	200
	V_{g0}	ml/r	0
Max. speeds (With Max. Permissible swept volume)	V_{gmax}	r/min	2900
	$V_{g < V_{g1}}$	r/min	4600
	V_{g1}	ml/r	126
	V_{g0}	r/min	5100
Max. Permissible. Swept volume	Q_{max}	L/min	580
Torque constants	V_{gmax}	Nm/MPa	31.8
Max. torque	V_{gmax}	Nm	1273
Filling capacity		L	2.7
Moment	J	kgm ²	0.0353
Weight(appro.)	M	kg	80

EP2 Electrical proportional control

Standard model: assembly type 2

start of control at V_{gmax} (maximum torque and minimum speed)

End of control at V_{gmin} (minimum torque, maximum speed)

EP2-control voltage 24VDC 200mA-600mA

If the operating pressure is less than 1.5Mpa, an auxiliary pressure of 1.5Mpa is required at port G. (The maximum control pressure allowable = 10MPa)

Electric control, with proportional solenoid EP2

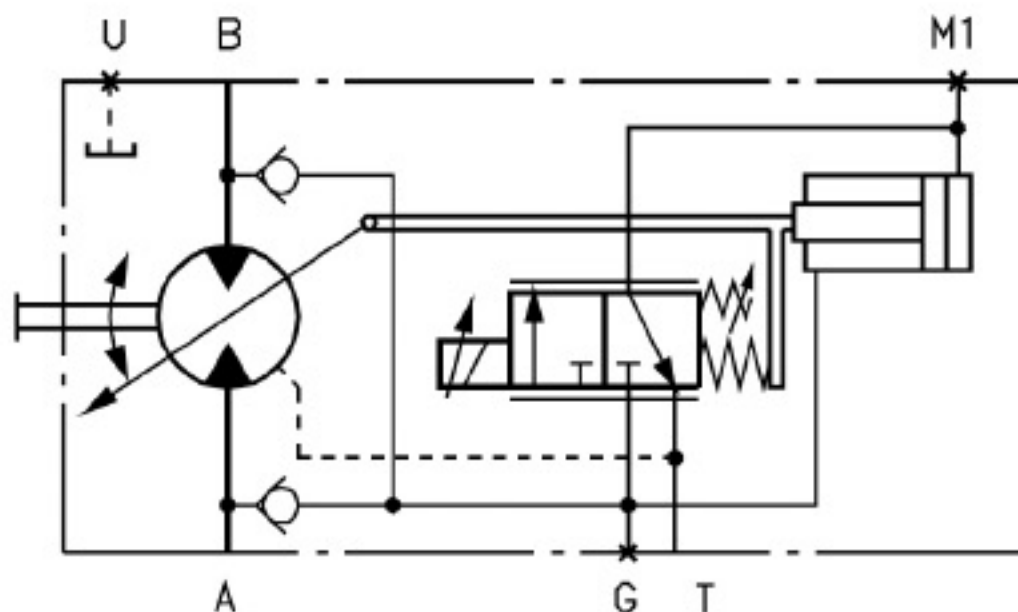

EP2.D pressure control, direct control

The pressure control overlays the EP function. If the load increases or a reduction in the swivel angle of the motor causes the system pressure to increase, the motor will start to swivel to a greater angle when the pressure reaches the setpoint value of the pressure control.

The increase in the displacement and the resulting reduction in pressure cause the control deviation to decrease. With the increase in displacement the motor develops more torque, while the pressure remains constant.

Setting range on the pressure-control value:

Size 200 8–40Mpa

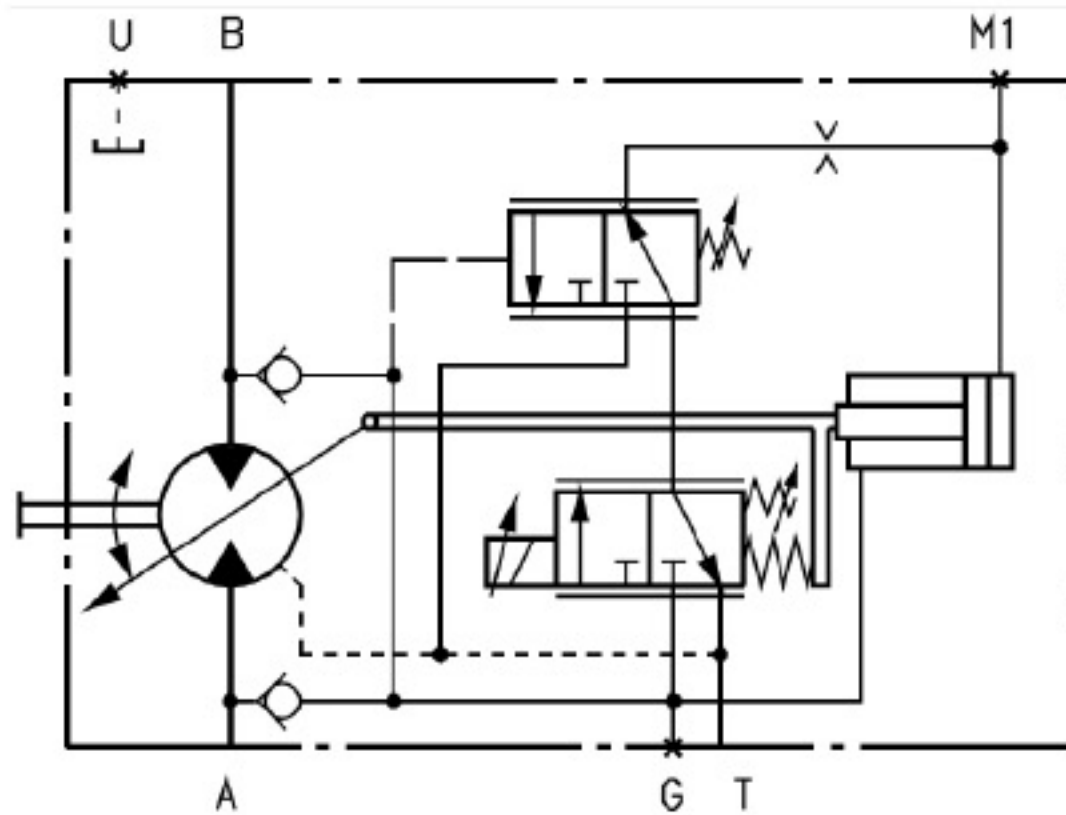

Variable Displacement Motor HD-A6V200

A6V200 MA-Unit Dim dimensions

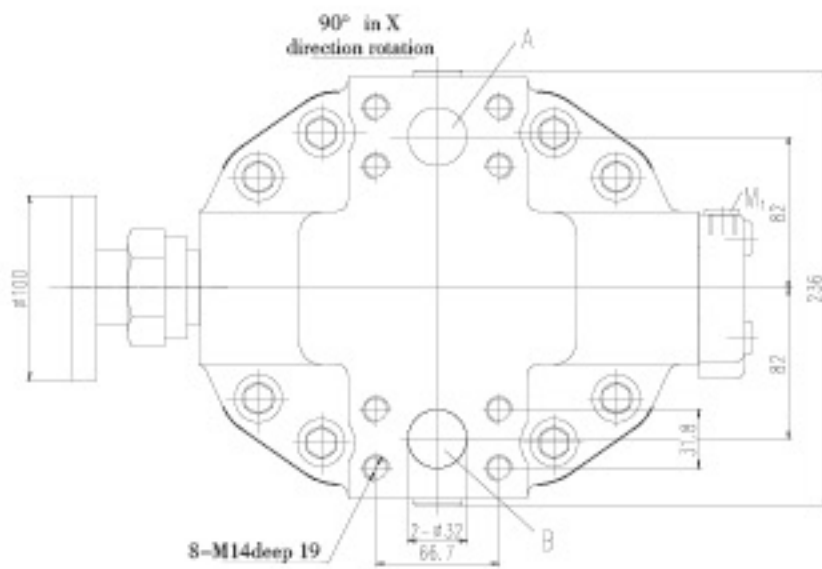
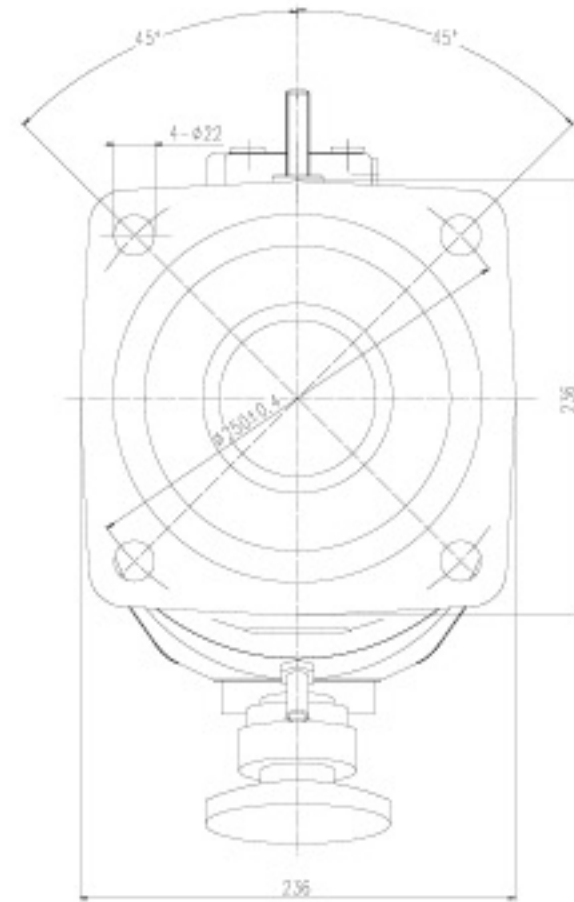
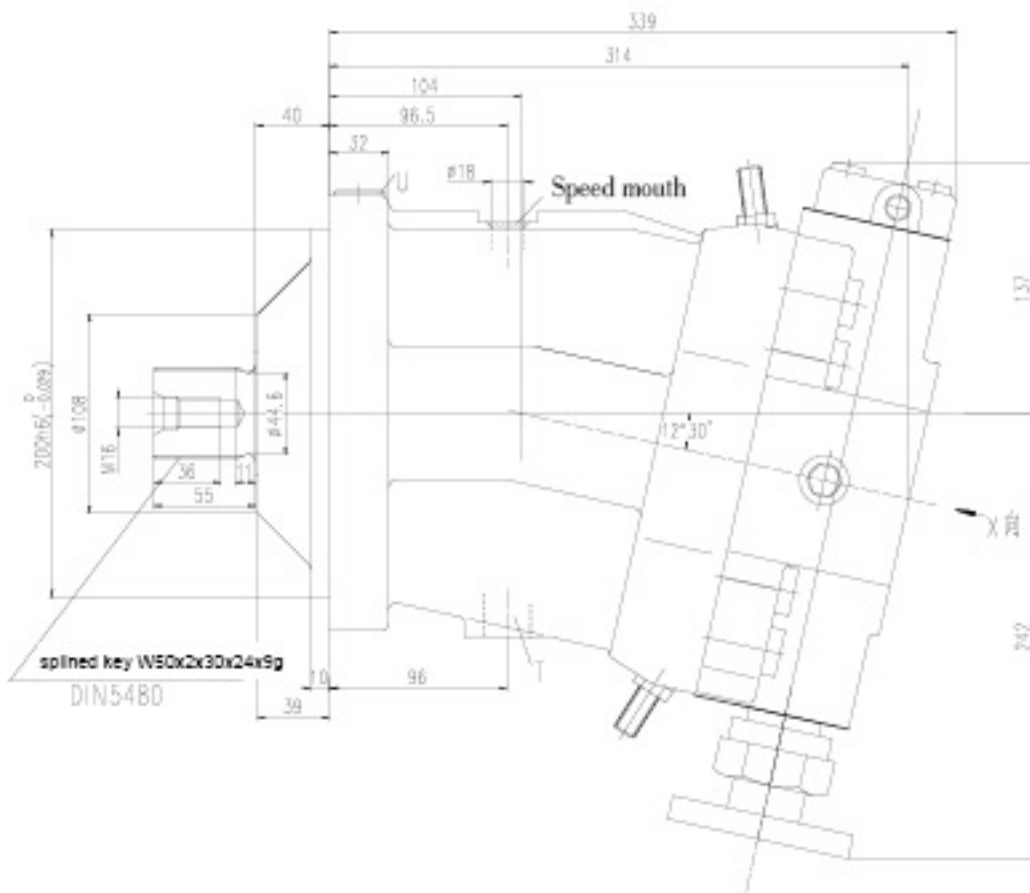

- A. B service lines SAE1 42Mpa
- G for synchronous control of several units and external
- Control pressure(plugged) M14x1.5
- T case drain port M26x1.5
- U oil change flushing M22x1.5
- M₁ control pressure measuring port (plugged) M14x1.5



 **Tel: 400-000-6987**

Our company has passed:

- ISO9001 Quality Managing System Certificate
- ISO14001 Environment Managing System Certificate
- OH SAS18001 Occupational Health Safety Managing System Certificate
- CE Certificate

Compiled by Huade Hydraulic Technical Center

 **Huade**

BEIJING HUADE HYDRAULIC INDUSTRIAL GROUP CO., LTD.

Compiled in Oct.2012